

Technical Specifications:

Grating Pitch	40µm
Accuracy (µ/m)	±5µ for Measuring steps up to 1 µ, ±10µ for Measuring steps of 5 µ and above.
Measuring Lengths	120, 170, 220, 270, 320, 370, 420, 470, 520, 620, 720, 820, 920, 1020, 1120, 1240, 1340, 1440, 1540, 1640, 1740, 1840, 1940, 2040mm
Current consumption	Typ. 150mA (250mA max)
Power supply	+ 5 VDC (± 5%)
Output signal	11 µA Current Output.
Reference mark	Every 25mm
Operating Temperature	0° C to 50° C
Storage Temperature	-20° C to 70° C
Relative Humidity	20% to 80% Non-condensing
Standard Cable length	3mtr Cable up to 820mm, 5mtr Cable above 820mm
Max. cable length	20 meters
Measurement Speed	50 KHz
Protection class	IP-54

Definitions:

Resolution: Resolution of a linear encoder is defined as the smallest measurable positional step. The resolution depends on the grating pitch of the scale and the interpolation factor set in the reader head. The quoted resolution (See table) is after x4 edge multiplication. For 1Vp-p resolution is determined by the interpolation of the user processing system.

Accuracy: The accuracy of the system is such that all positional data-points about the mean error fall within the specified limits for any 1m travel. The reference temperature for the accuracy class is considered as 20° C.

Pin Connection Details:

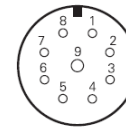

9 Pin round type Plug connector

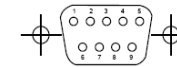

9 Pin 'D' type Plug connector



STATIC SENSITIVE DEVICE
OBSERVE HANDLING
PRECAUTIONS

11 µA Current Output

Pin	7	8	3	Body	4	1	2	6	5
Pin	1	2	3	4	5	6	7	8	9
Signal	+ I0	- I0	VCC	Shield	GND	+ I1	- I1	- I2	+ I2
Armoured Colour	Grey	Brown	Black	Violet	White	Pink	Red	Green	Yellow
Non-Armoured Colour	Brown	Black	White	Violet	Blue	Red	Orange	Green	Yellow

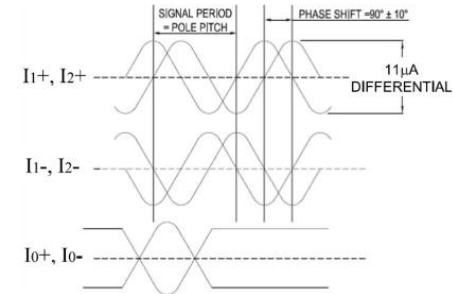

Dimensions:

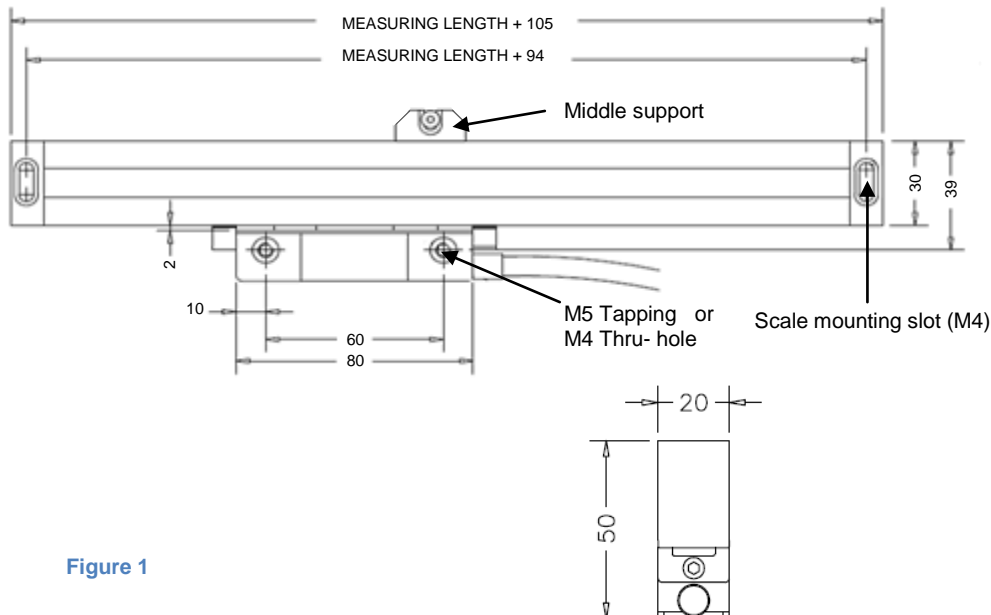

Figure 1

Mounting Tolerances:

Scale: Scale should be aligned with in 0.1mm/m from front side and top side. This alignment should be closer to zero for better results.

Reader head: Standard gap between reader head and scale should be as per given in Figure 2. Plastic support blocks are provided to maintain this gap between reader head and scale during installation. Refer Figure 2 for further alignment data.

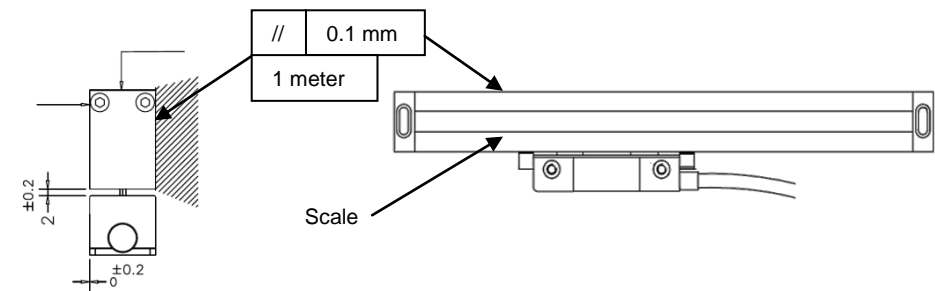

Figure 2

Mounting Instructions:

Attention:

- Prior to mounting clean the mounting area thoroughly of oil, dust, coolant, and burr.
- Ensure the reader head mounting allows the reader head to move freely over the length of the scale.

Mounting the Scale:

- The best location for mounting the scale is as near to the centerline of the slide, or as close to the guide-ways of the machine as possible.
- If the mounting surface of the machine is even (within 0.1mm/m), then the scale can be directly mounted to the machine. Ensure the parallelism to full length of the scale as instructed in the mounting tolerances using a dial indicator. Refer Figure 5.
- If the mounting surface is not even (more than 0.1mm/m) then it is recommended to use the optional scale mounting brackets.
- Mounting brackets should be positioned at the two ends of the scale as shown in the Figure 5. The alignment of the blocks should be checked using dial indicator before mounting the scale. Use middle support as indicated in Figure 5 at every 500mm.
- Ensure the supplied cover is properly mounted to protect the scale and reader head for the entire length to ensure the reliability and performance of the system. Refer Figure 5.

Mounting of Reader head:

- The reader-head mounting bracket should be installed as per Figure 4 such that correct gap is maintained between the reader head and the scale.
- Reader head has M5 tapping available such that M5 screws can be directly fitted. Optionally M4 screws can be used as through hole. Refer Figure 4.

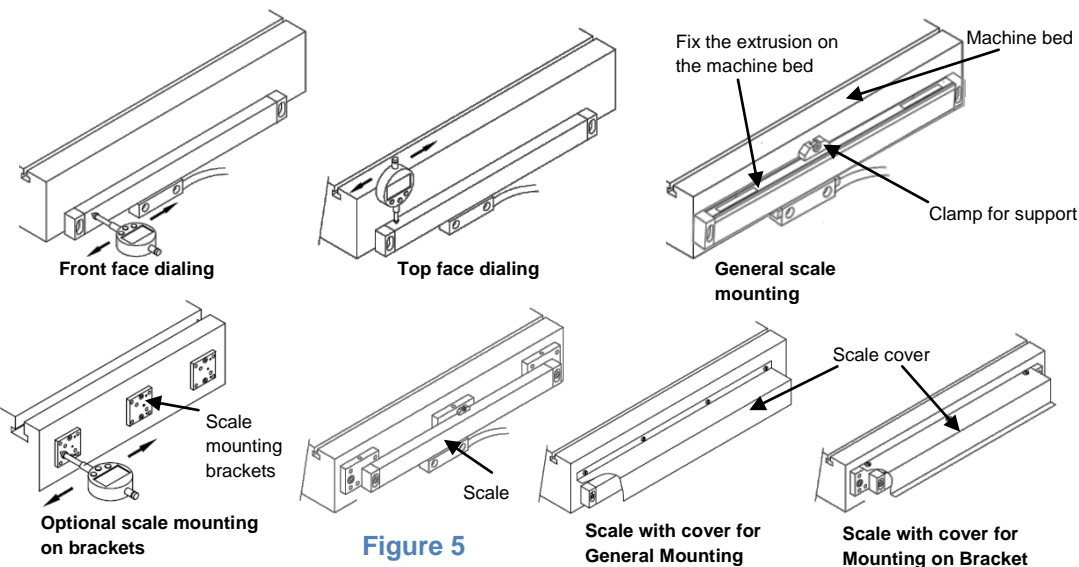

Figure 5

Inspection of Mounting:

Move the slide over the full range of motion to make sure that full machine travel can be obtained without the reader head contacting the scale end brackets. Otherwise the reader head will be damaged. Make sure that the plastic support blocks at the side of reader head are removed after installation.

Cable Routing:

- Cable should be routed such that it does not come in between the machine moving parts.
- The bending radius should not be less than 60mm as shown in the Figure 3.
- The encoder cables should not be routed close to high power or high voltage switching sources.
- Where extension leads are used the connectors should be mounted clear of any source of liquid contamination.

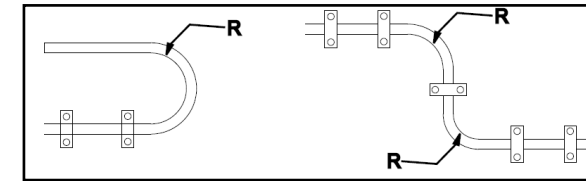

Figure 3

Safety:

- Avoid using source of liquid contamination near glass scale any time during its use or during maintenance. This may damage the scale permanently.

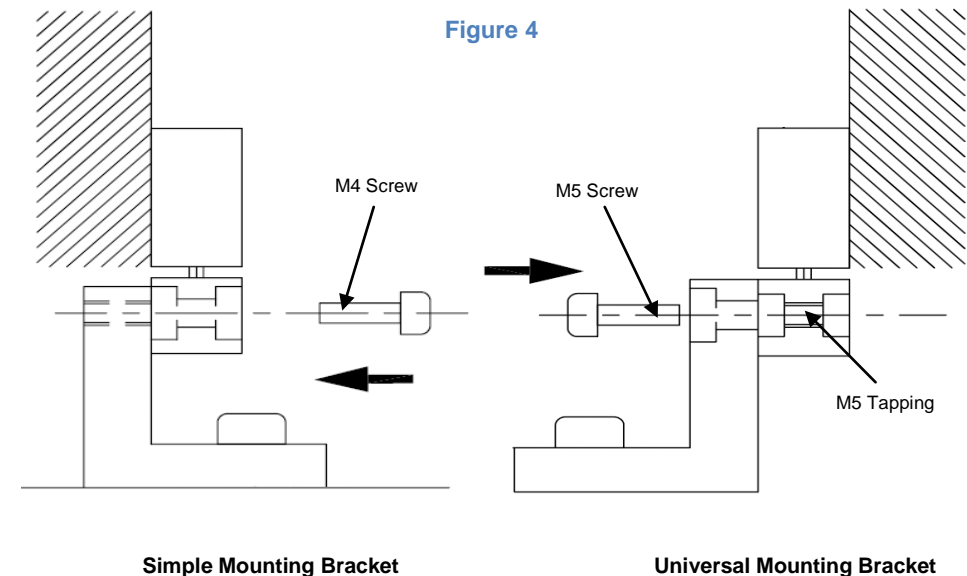

Figure 4

Electronica Mechatronic Systems (India) Pvt. Ltd.

Web: www.electronicaems.com; email: info@electronicaems.com

Code: 0073-14-1010

Update Date: 24th March, 2009