

Technical Specifications

Display Unit

Measuring Units	mm, Inch Degrees (Angular mode)
Resolution	10µm, 100µm
Measuring Length	± 9.99 meters
Battery Type	2 X 1.5V "AA" size
Battery Life	1 year*1
Keypad	5 keys Membrane type
Display	8 digit LCD display
Operating Temperature	0° C to 55° C
Overall Size	102mm (W) X 65mm (H) X 48.5mm (D)
Panel Cut Out Dimensions	96.5mm (W) X 59.5mm (H)

*1 – The battery life is calculated considering the battery capacity of 1500mAh and average usage of 8hrs daily.

Sensor Unit

Tape Pole Pitch	2.5mm
Sensor Dimensions	25mm (W) X 15mm (H) X 10mm (D)
Cable Length	2 meter Standard (Fixed)

Battery replacement:

To change the batteries refer to the following figures. While replacing the batteries please pay attention to correct polarity. The polarity is marked inside the battery holder. The batteries are size "AA", 1.5V.

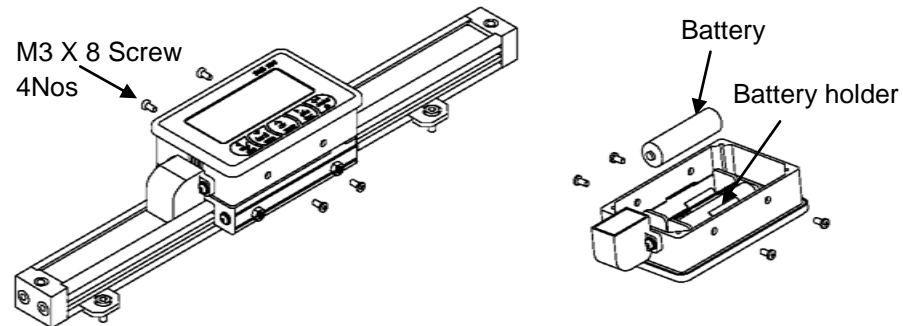
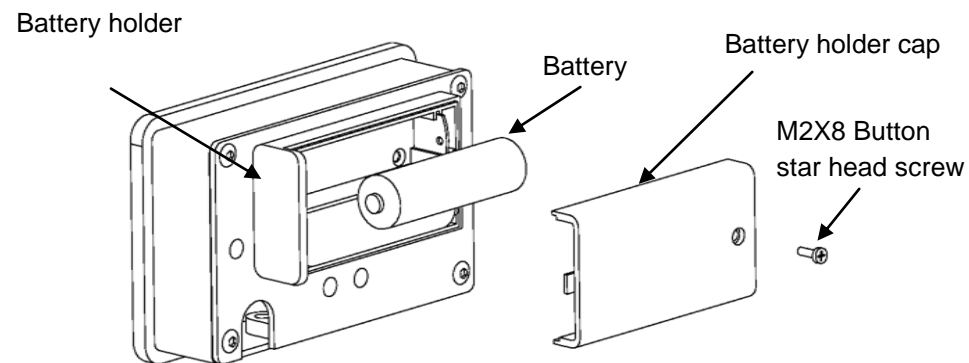

1. Remove the screws from both sides.
2. Lift DRO casing and replace the batteries which are under the LCD.
3. Values prior to battery replacement can be saved by pressing key and till is active pressing key .



Keyboard



Selects RADIAL / DIAMETRIC mode. Also acts as a "Left" key.



Selects INCH / MM / Angular mode. Also acts as "DOWN" key.



"Zero" key to reset axis only in Incremental mode. Also used as "CANCEL" key to exit from Menu and "UP" key.



Selects ABSOLUTE / INCREMENTAL mode. Also acts as a "RIGHT" key.



"FUNCTION" key. Also acts as a "ENTER" key.

LCD Display



Indication for key press.



Intimation for key press



Low battery indication.



Angular Measurement mode.



Radial mode



Current incremental counter number.



Diametric mode



Absolute counting mode



Incremental counting mode



Inch measurement mode



mm measurement mode



Current absolute counter mode

Diagnostic mode

The LCD DRO has intelligent Real Time diagnosis of certain parameters and indicates to the user when respective events occur.



Low Battery Indication () – When the battery voltage drops below usable range this indication is turned on the LCD display. The user has 2-3 days time to replace the batteries before the system turns OFF.



Sensor Error (*Error 1*) – Whenever the sensor gets disconnected from the DRO by accident, the DRO displays "Error 1" message on the LCD.



Tape Error (*Error 2*) – Whenever the gap between the magnetic tape and reader head increases above its mounting tolerance, then the DRO displays "Error 2" message on the LCD indicating the tape error.

Installation Diagrams

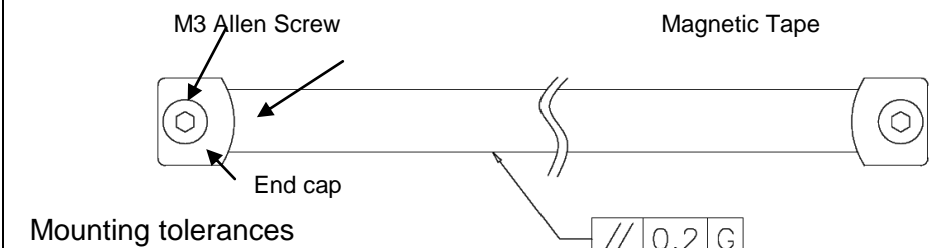
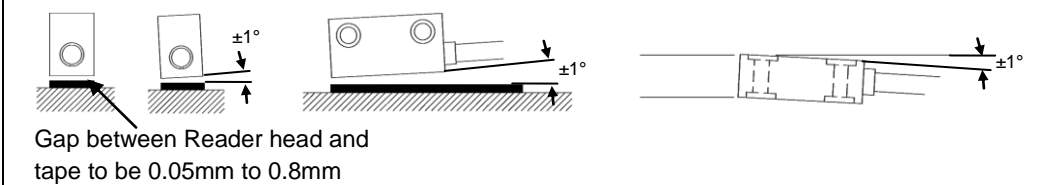
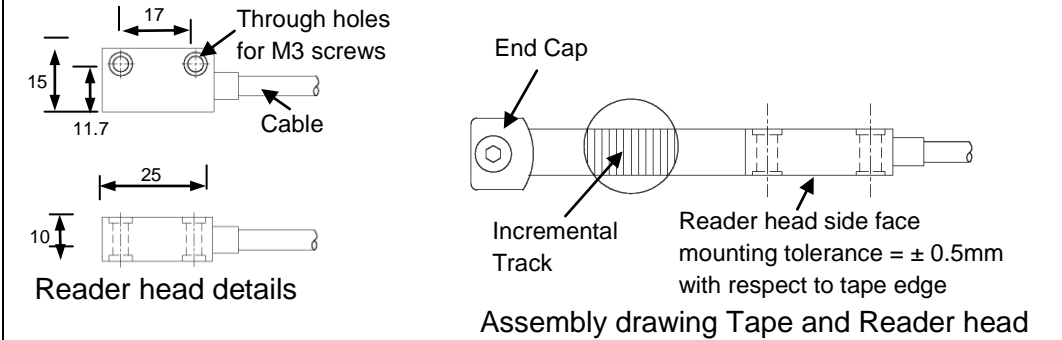
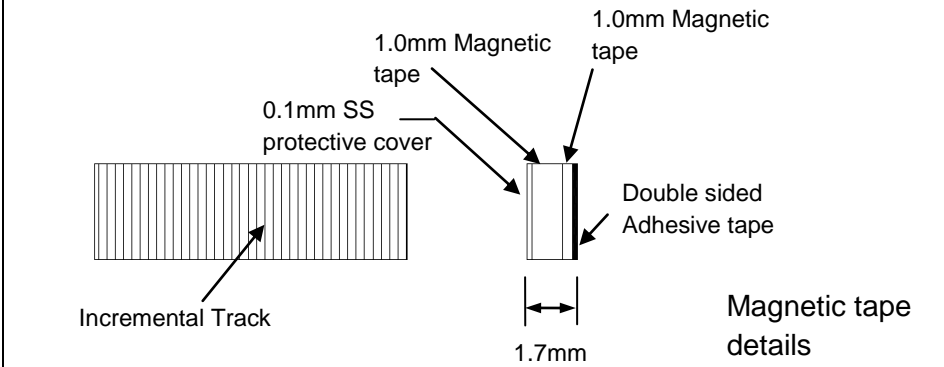

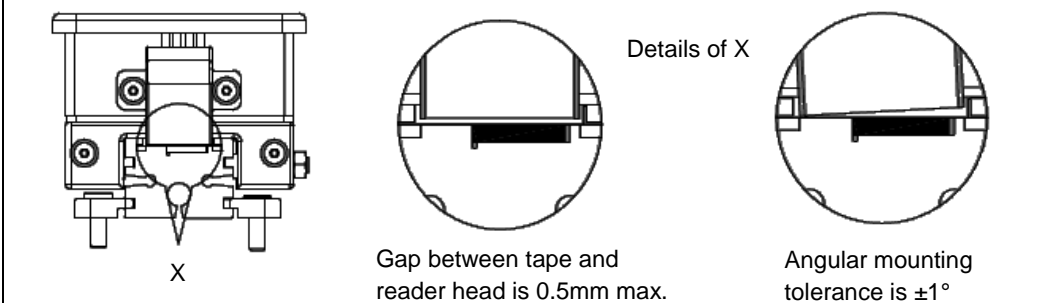
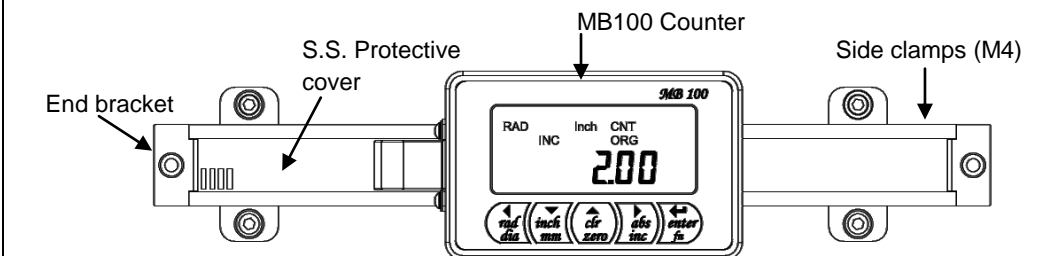

Installation diagram for Guided System (DDFZ-6A-XXXX)



Setup

 Press for 5 seconds to enter Setup
5 sec

  Toggle within the Setup parameters

 To enter into the selected parameter



 To go to the previous menu to exit from setup.



Setup parameters

Parameter	options	Description
d ir	LEFT, r ight	Sets the direction of counting
d is rES	10 u, 100 u	Sets the display resolution
SEt rEF	1.234 ¹	Sets new reference
SEt oFFS	1.234 ¹	Sets 4 tool offsets
LEC ²	1.234 ¹	Sets linear error compensation
AngULAr	--	Sets angular mode parameters
rAd iUS	123.456 ¹	Sets radius in angular mode
rES	1, 0.1, 0.01	Sets angular resolution in degrees under angular mode
SYSLEn	--	Configures System parameters (password protected)
CAL ib	--	Enters into Sensor calibration mode (password protected)
uEr 1.3	--	Displays current Software version

Numeric Entry

Where-ever numeric entry is required the user should follow following sequence to enter a number.
The display will show "0000.00" with right most digits blinking when the DRO is expecting a numeric entry.

Use  and  key to select the digit position.

Use  and  key to select the value for the selected digit.

Use  to finish the numeric entry and set the desired value.

LEC (Linear Error Compensation)

This correction factor is in the range of 0.001 to 9.999. The value entered is multiplied to the measured value. This correction factor is entered using numeric entry.

Press  to save the entered LEC value.

The default LEC value is 1.000.

Example:



Current Value = 12.50mm
LEC = 1.010
New corrected value = 12.50 X 1.010 = 12.63mm





System Parameters

Select "555" as a password to enter the System parameters Menu.

Following options are available

Keyboard Enable / Disable – Individual keys can be enabled / disabled using this parameter. The "1234 En" or "1234 d is" message is displayed on the screen. The toggling number indicates specific keys as per list given below.





The numbers can be scrolled by  and .
The Enable / disable can be scrolled using .

Display	Description
1	 key
2	 key
3	 key
4	 key
d ir	Direction mode in setup
rES	Resolution mode in setup
rEF	Absolute reference mode in Setup
oFFS	Offsets mode in Setup
LEC	Linear error compensation in Setup
Ang	Angular mode in Setup

Sensor calibration mode

This is a factory setting mode in which the reader head gets calibrated automatically.

Power off modes to save battery consumption

Auto power off mode is activated when DRO is idle for a long time (2 hrs approximately). User can also manually switch off the DRO with following key sequence. Press  & till  is active press  key. Sometimes values needs to be saved for reference such as during battery replacement. This can be done with  &  key sequence only.

Note:

If DRO is in OFF mode and the reader head is moved then previous datum is lost and display shows wrong reading.

DRO Functions

Absolute (ABS) mode

The ABS icon indicates that the DRO is running in this mode. This mode consists of one basic counter and 4 different offsets. The basic counter is related to the machine zero and its value is programmed in Setup mode as REFERENCE value.

Example

Current display = 10.48mm
Reference value = 100.00mm

Keeping the  key pressed, press  key once to load the reference value.

The current display will show 100.00mm.

The programmed offsets can be applied as given below

Keeping the  key pressed, press  key to select the desired offset counter.

The offsets get applied as shown in the figure:

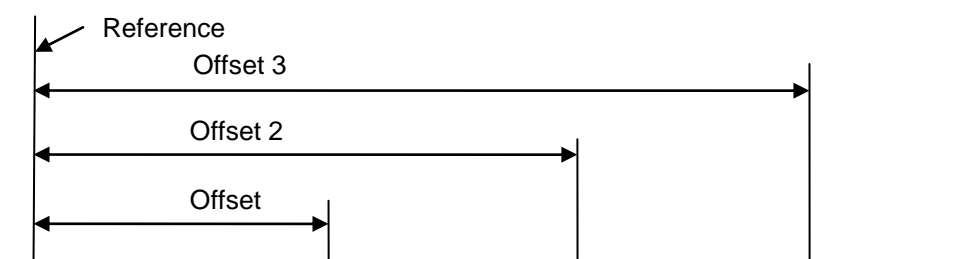

Note: The counters cannot be reset in this mode.

Incremental (INC) mode

The INC icon indicates that the DRO is running in this mode. This mode consists of 5 different incremental counters. The counter in use is indicated by **CNT 0 1 2 3** icon. The base incremental counter is indicated by **CNT** without any number.

Example

Keeping the  key pressed, press  key to select the desired counter.

These counters are independent and can be reset anywhere using the  key. After reset the counter shows the value relative to the point where it had been reset.

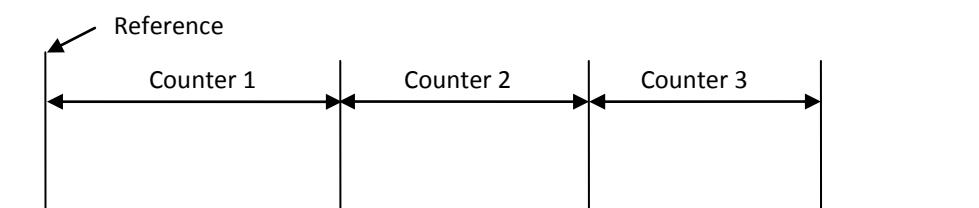

Radial / Diametric mode

This mode is used to convert radial mode display into diametric mode display and vice versa with the help of  key.

Inch / mm / Degree mode

Using  key, the measurement units can be toggled between Inch, mm and degrees (angular) mode. The degrees unit is only possible in case of a non-zero radius value in setup mode.