



MT100 DRO Operational Manual

Application

The MT100 DRO is specially designed for angular applications such as measuring head tilting angle in milling machine and other such applications. The MT100 DRO should be used in applications where full 360° is not required. The magnetic tape can be mounted on the round surface because of its flexibility and the MT100 sensor is mounted on this tape such that it moves on the tape as the slide is rotated. The MT100 display will show the angle in degrees in the range -180.00° to +180.00°.

Technical Specifications

Display Unit

Measuring Units	Degrees
Resolution	0.01°
Battery Type	2 X 1.5V "AA" size
Battery Life	1 year (Typical)
Keypad	5 keys Membrane type
Display	8 digit LCD display
Operating Temperature	0° C to 55° C
Overall Size	102mm (W) x 65mm (H) x 48.5mm (D)
Panel Cut Out Dimensions	96.5mm (W) x 59.5mm (H)

Sensor Unit

Tape Pole Pitch	2.5mm
Sensor Dimensions	20mm (W) x 15mm (H) x 10mm (D)
Cable Length	350mm Standard

Battery replacement:

To change the batteries refer to the following figures. While replacing the batteries please pay attention to correct polarity. The polarity is marked inside the battery holder. The batteries are size "AA", 1.5V.

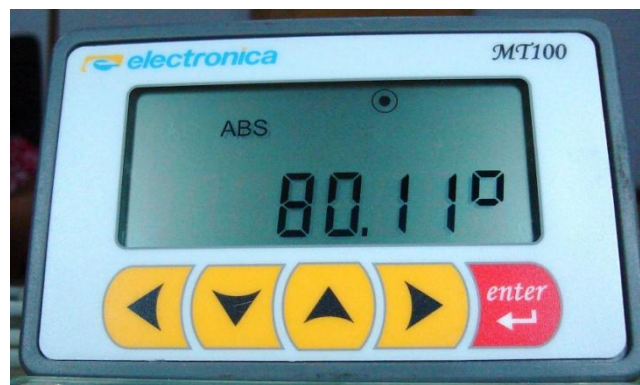
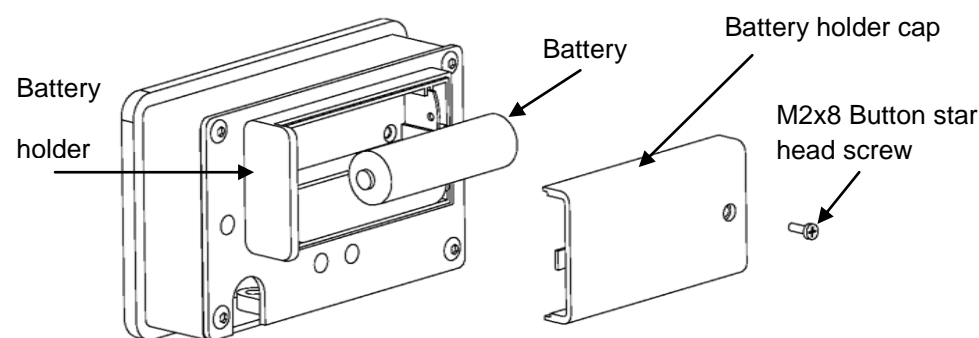

Keyboard

- "Left" key.
- "DOWN" key.
- "Zero" key to reset axis and "UP" key.
- "RIGHT" key.
- "ENTER" key.

LCD Display

- Indication for key press.
- Low battery indication.
- Angular Measurement mode.
- Absolute counting mode

Diagnostic mode





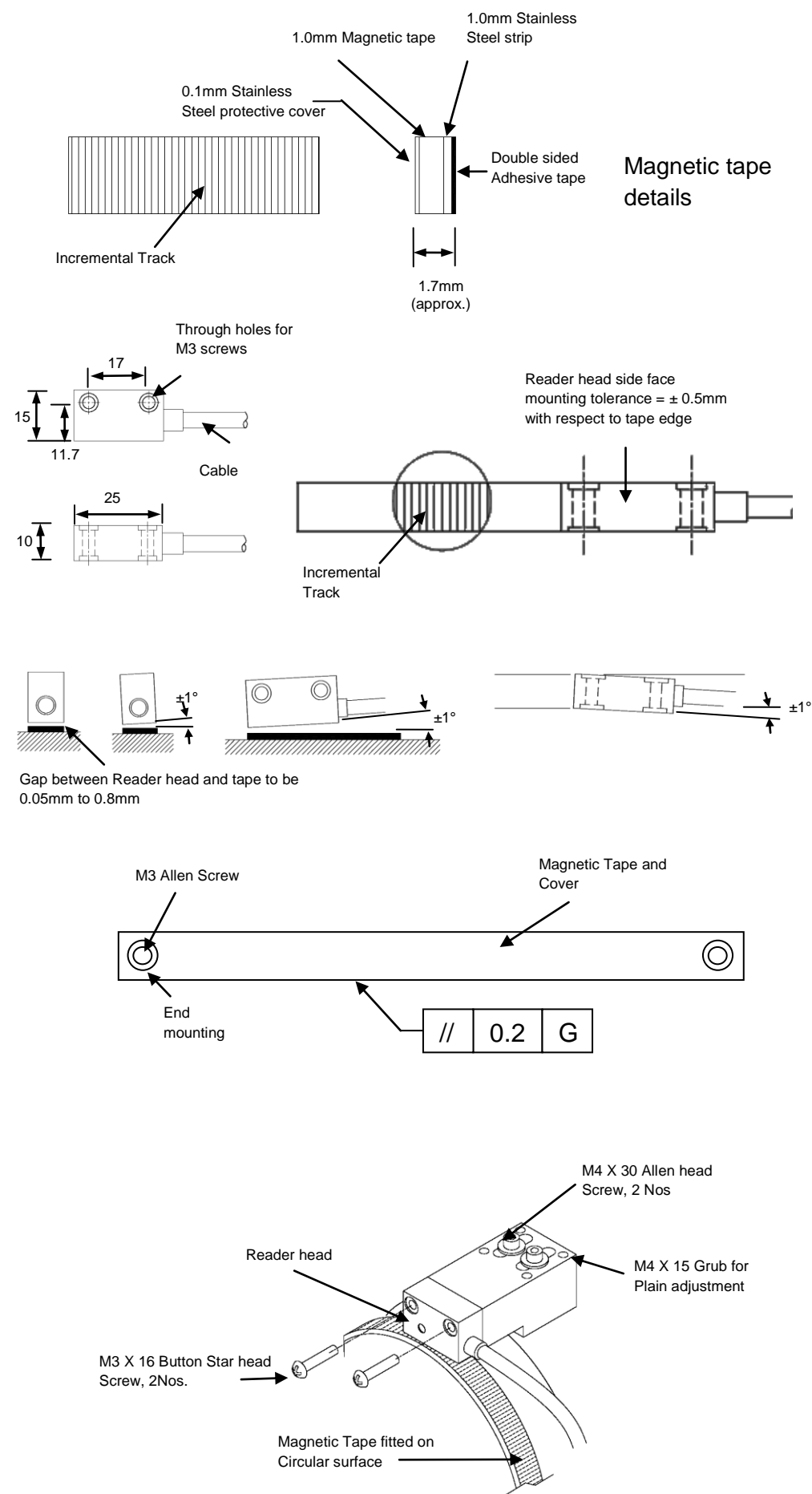

The MT100 DRO has intelligent Real Time diagnosis of certain parameters and indicates to the user when respective events occur.

- Low Battery Indication () – When the battery voltage drops below usable range this indication is turned on the LCD display. The user has 2-3 days time to replace the batteries before the system turns OFF.
- Sensor Error (*Error 1*) – Whenever the sensor gets disconnected from the DRO by accident, the DRO displays "Error 1" message on the LCD.
- Tape Error (*Error 2*) – Whenever the gap between the magnetic tape and reader head increases above its mounting tolerance, then the DRO displays "Error 2" message on the LCD indicating the tape error.

Installation Diagrams

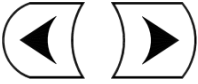

Setup

-  Press for 5 seconds to enter Setup
-  5 sec
-  Toggle within the Setup parameters
-  To enter into the selected parameter
-  To enter into the selected parameter
-  To go to the previous menu and to exit from setup.
-  To go to the previous menu and to exit from setup.



Setup parameters



Parameter	options	Description
dir	LEFT, right	Sets the direction of counting
radius	123.45	Sets radius for the DRO calibration. Enter the radius of the surface on which the magnetic tape is fitted.
CAL FAC	123.45	Displays current Calibration factor. This can be edited manually.
CAL pb	--	Password protected mode for sensor calibration

Numeric Entry

Wherever numeric entry is required the follow following process of data entry is to be used:

The display will show "0000.00" with right most digits blinking when the DRO is expecting a numeric entry.

Use  and  key to select the digit position.

Use  and  key to select the value for the selected digit.

Use  to finish the numeric entry and set the desired value.

Angular Calibration

The angular calibration can be done using two methods:

1. Radius Entry
2. Calibration factor entry

Radius Entry

In this mode of calibration, the user can enter the radius of the surface on which the magnetic tape is fixed.

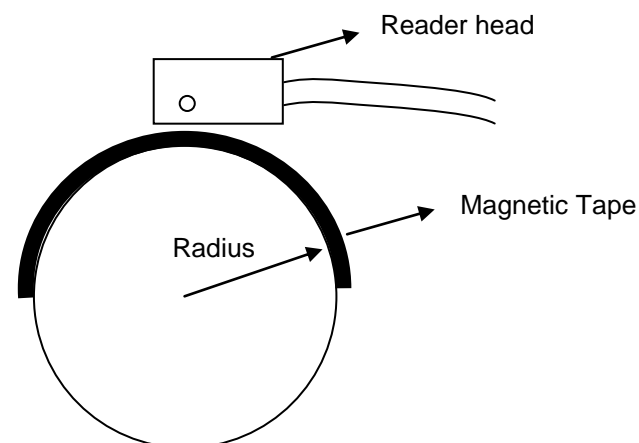

The previous radius is first displayed. Press  to edit. Refer to the numeric entry mode to enter the desired calibration factor.

Calibration factor Entry

The calibration factor is calculated as given in the formula below

$$\text{Calibration factor} = \frac{2 \times \pi \times R \times 100}{360}$$

Where **R** is radius in mm

The user can calibrate the angular axis by calculating the calibration factor. The previous calibration factor is first displayed on the display.

Press  to edit. Refer to the numeric entry mode to enter the desired calibration factor.



Calibration Procedure

- Step 1: Measure the radius of the surface on which the magnetic tape is to be fixed.
- Step 2: Enter the radius in to the DRO.
- Step 3: Check the angular display by comparing it with a known standard angle.
- Step 4: If some deviation is observed, change the calibration factor as discussed earlier as per the sign of the deviation. If the observed reading is less than the true reading increase the calibration factor proportionately and vice versa.
- Step 5: Repeat step 3 and 4 until the desired readings are obtained.

Sensor calibration mode

This is a factory setting mode in which the reader head gets calibrated automatically.

DRO Functions

-  Display Reset – The Display can be reset by using  key in normal operation mode. Using this will change the datum. Previous datum cannot be restored.
-  Display Range – The MT100 DRO displays the angle in decimal degrees only. The display range is -180.00° to +180.00°. The display gets reset if it goes beyond range.

Safety

-  Avoid using a magnetic stand or any permanent magnet close to the magnetic scale any time during its use or during maintenance as this may permanently damage the magnetic scale.