

Technical Specifications:

Pole Pitch	2mm
Resolutions (X4 edge)	5µm
Accuracy (µm)	±10µ
Repeat accuracy	± 1 count
Measuring Lengths	170, 220, 270, 320, 370, 420, 470, 520mm
Current consumption	Typ. 150mA (250mA max)
Power supply	+ 5 VDC (± 5%)
Output signal	Differential Line driver as per EIA RS422 standards.
Reference mark	Single At 30mm from cable exit side
Operating Temperature	0° C to 50° C
Storage Temperature	-20° C to 70° C
Relative Humidity	20% to 80% Non-condensing
Standard Cable length	0.5 meter 3 meter extension cable optional
Max. cable length	20 meter
Measurement Speed	2MHz (10m/s @ 5µm)

Definitions:

Resolution: Resolution of a linear encoder is defined as the smallest measurable positional step. The resolution depends on the grating pitch of the scale and the interpolation factor set in the reader head. The quoted resolution (See table) is after x4 edge multiplication. For 1Vp-p resolution is determined by the interpolation of the user processing system.

Accuracy: The accuracy of the system is such that all positional data-points about the mean error fall within the specified limits for any 1m travel. The reference temperature for the accuracy class is considered as 20° C.

Dimensions:

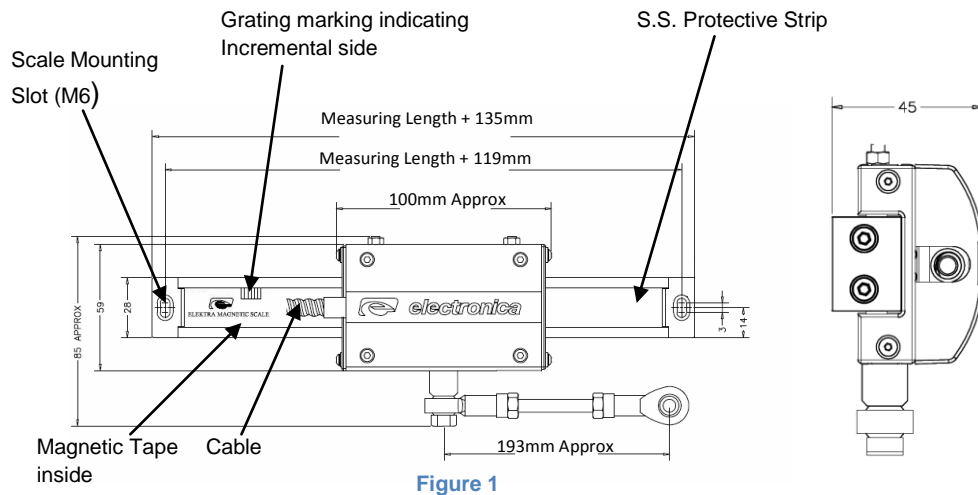

Figure 1

Pin Connection Details:

9 Pin 'D' type Plug connector

STATIC SENSITIVE DEVICE
OBSERVE HANDLING PRECAUTIONS

RS422

Pin	1	2	3	4	5	6	7	8	9
Signal	GND	- A	- B	- Z	VCC	+ A	+ B	+ Z	Shield
Colour	White	Red	Green	Brown	Black	Pink	Yellow	Gray	Violet

EMRB – for 2mm Pole Pitch

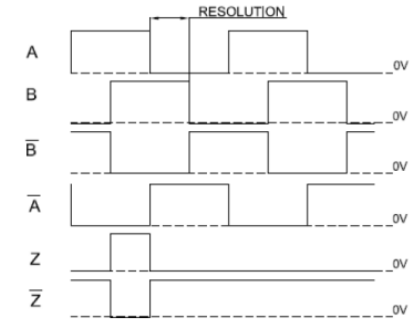

Mounting Tolerances:

Scale: Scale should be aligned with in 0.2mm/m from front side and top side. This alignment should be closer to zero for better results. Check the parallelism of scale mounting surface with respect to moving member of the machine. It should be within 0.5mm/meter

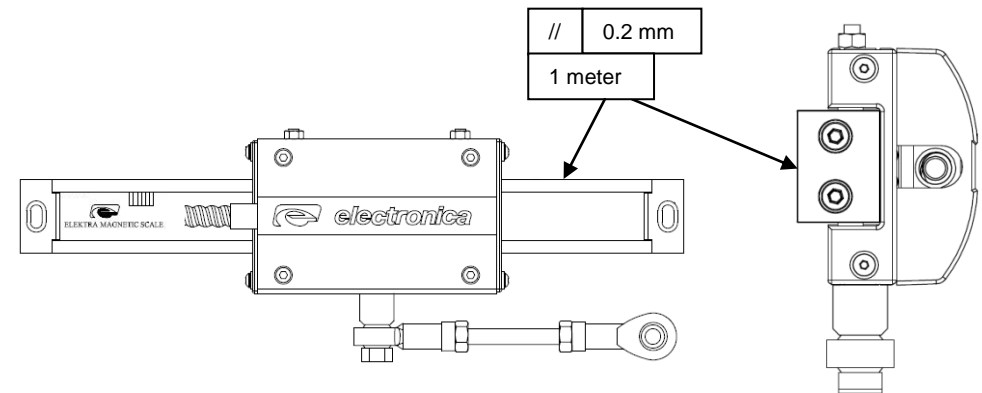

Figure 2

Mounting Instructions:

Attention:

- Prior to mounting clean the mounting area thoroughly of oil, dust, coolant, and burr.
- Ensure the reader head mounting allows the reader head to move freely over the length of the scale.

Mounting the Scale:

- ☞ The best location for mounting the scale is as near to the centerline of the slide, or as close to the guide-ways of the machine as possible.
- ☞ If the mounting surface of the machine is even (within 0.2mm/m), then the scale can be directly mounted to the machine. Ensure the parallelism to full length of the scale as instructed in the mounting tolerances using a dial indicator. Refer Figure 5.
- ☞ If the mounting surface is not even (more than 0.2mm/m) then it is recommended to use the optional scale mounting brackets.
- ☞ Mounting brackets should be positioned at the two ends of the scale as shown in the Figure 5. The alignment of the blocks should be checked using dial indicator before mounting the scale.

Carriage mounting options

- Without link – Carriage can be directly mounted.
- With link – Carriage can be mounted using universal link as shown in figure 4.
- With flexible bracket – Carriage can be mounted using flexible bracket as shown in figure 4.

Safety:

- ☞ Avoid using the magnetic stand or any permanent magnet close to the magnetic scale any time during its use or during maintenance. This may damage the magnetic scale permanently.

M6 mounting slot

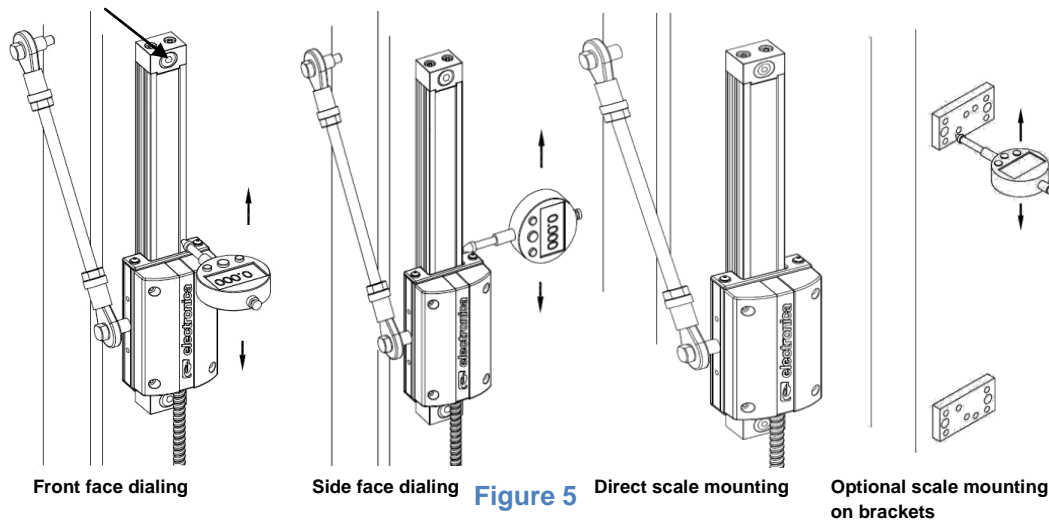

Inspection of Mounting:

Move the slide over the full range of motion to make sure that full machine travel can be obtained without the reader head contacting the scale end brackets. Otherwise the reader will be damaged.

Cable Routing:

- ☞ Cable should be routed such that it does not come in between the machine moving parts.
- ☞ The bending radius should not be less than 60mm as shown in the Figure 3.
- ☞ The encoder cables should not be routed close to high power or high voltage switching sources.
- ☞ Where extension leads are used the connectors should be mounted clear of any source of liquid contamination.

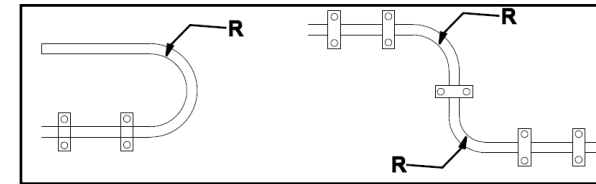

Figure 3

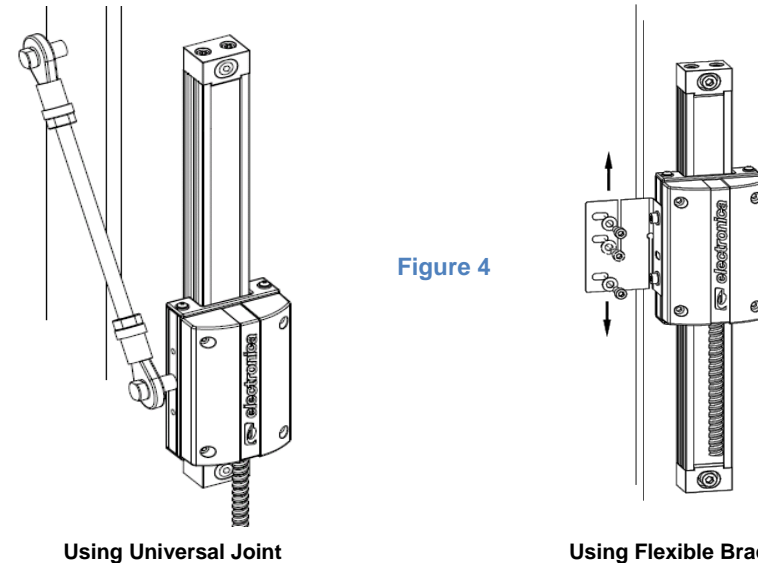

Figure 4

Electronica Mechatronic Systems (India) Pvt. Ltd.

Web: www.electronicaems.com; email: info@electronicaems.com

Code: 0073-14-1020

Update Date: 30th March, 2009