

Technical Specifications:

Pole Pitch	1mm/2mm/5mm
Resolutions (X4 edge)	1µm, 5µm, 10µm, 20µm, 50µm, 100µm
Accuracy (µ/m)	±10µ, ±20µ, ±50µ, ±100µ
Repeat accuracy	± 1 count
Measuring Lengths	Up to 20m
Current consumption	Typ. 150mA (250mA max)
Power supply	+ 5 VDC (± 5%)
Output signal	Differential Line driver as per EIA RS422 standards. 1Vp-p Sine wave output. (0.6Vp-p – 1.2Vp-p)
Reference mark	Every 50mm
Operating Temperature	0° C to 50° C
Storage Temperature	-20° C to 70° C
Relative Humidity	20% to 80% Non-condensing
Standard Cable length	3 meters armoured cable
Max. cable length	20 meters
Measurement Speed	2MHz (10m/s @ 5µm) 1Vp-p – 10KHz
Protection class	IP-67 for Reader Head

Definitions:

Resolution: Resolution of a linear encoder is defined as the smallest measurable positional step. The resolution depends on the grating pitch of the scale and the interpolation factor set in the reader head. The quoted resolution (See table) is after x4 edge multiplication. For 1Vp-p resolution is determined by the interpolation of the user processing system.

Accuracy: The accuracy of the system is such that all positional data-points about the mean error fall within the specified limits for any 1m travel. The reference temperature for the accuracy class is considered as 20° C.

Dimensions:

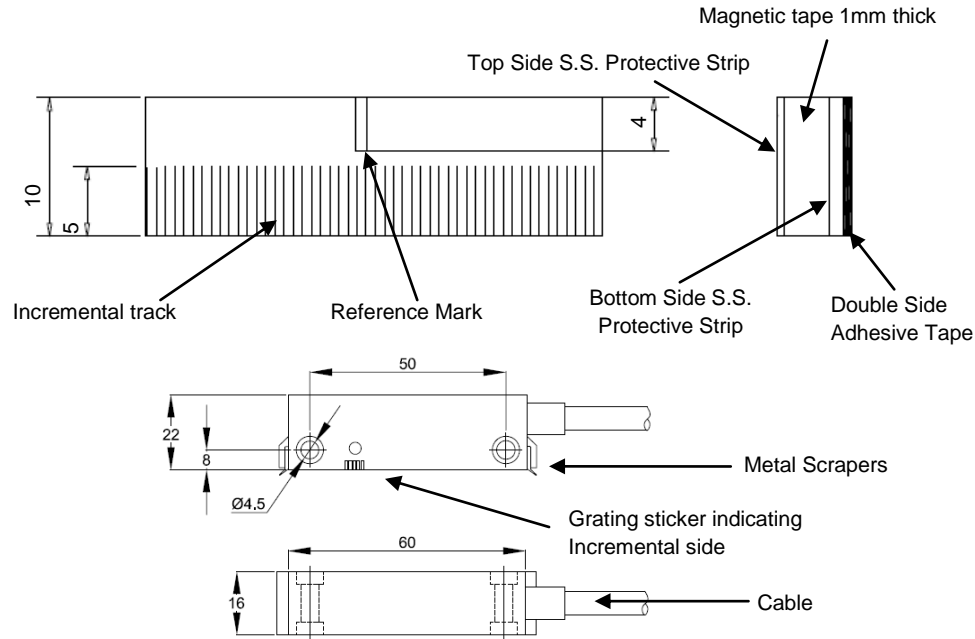
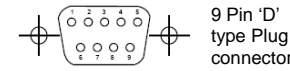

Figure 1

Pin Connection Details:



9 Pin 'D' type Plug connector



STATIC SENSITIVE DEVICE
OBSERVE HANDLING
PRECAUTIONS

RS422

Pin	1	2	3	4	5	6	7	8	9
Signal	+ Z	- Z	VCC	Shield	GND	+ A	- A	- B	+ B
Colour	Grey	Brown	Black	Violet	White	Pink	Red	Green	Yellow

1Vpp

Pin	1	2	3	4	5	6	7	8	9
Signal	V0+	V0-	VCC	Shield	GND	V1+	V1-	V2-	V2+
Colour	Grey	Brown	Black	Violet	White	Pink	Red	Green	Yellow

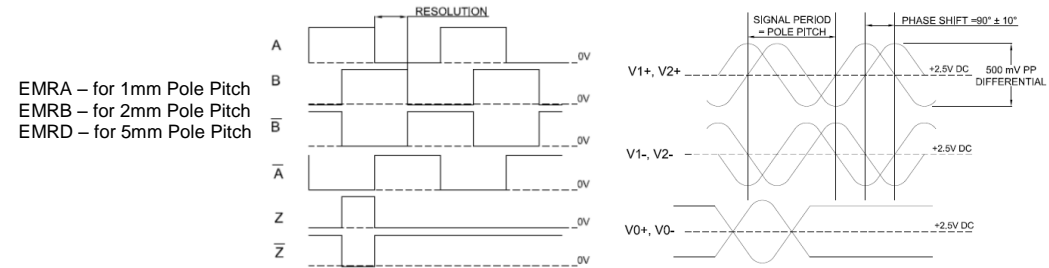

Mounting Tolerances:

Tape: Tape should be aligned with in 0.1mm/m from front side and top side. This alignment should be closer to zero for better results.

Reader head: Standard gap between reader head and tape should be as shown in table in figure 2. Plastic shim is provided to maintain this gap between reader head and tape during installation. Refer Figure 2 for further alignment data.

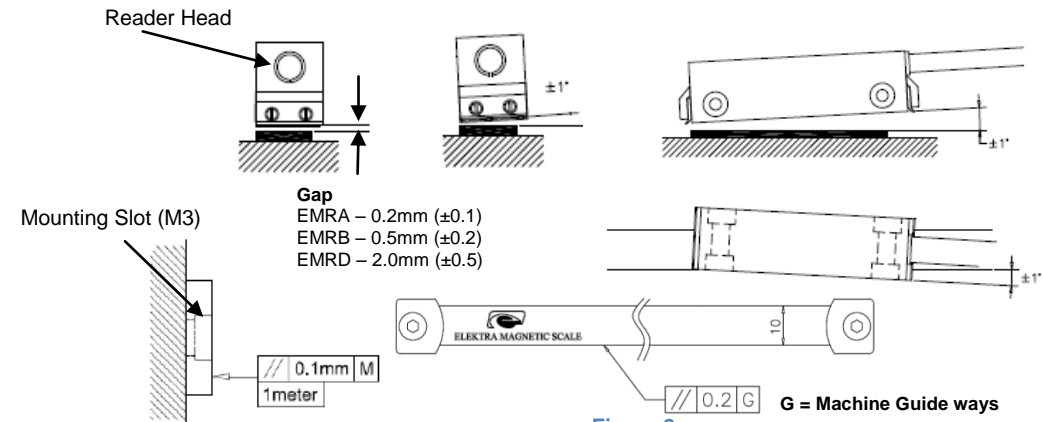

Figure 2

G = Machine Guide ways

Mounting Instructions:

Attention:

- Prior to mounting clean the mounting area thoroughly of oil, dust, coolant, and burr.
- Ensure the reader head mounting allows the reader head to move freely over the length of the tape.

Mounting the Tape:

- The best location for mounting the tape is as near to the centerline of the slide, or as close to the guide-ways of the machine as possible.
- If the mounting surface of the machine is within 0.1mm/m, mounting the tape on the machine. Ensure the parallelism to full length of the tape as instructed in the mounting tolerances using a dial indicator.
- Protective S.S. strip is provided along with magnetic tape. Fix protective S.S. strip on magnetic tape as shown in Figure 5. Peel off adhesion cover at the backside of S.S. strip.
- Fix both ends of the tape using supplied end caps and M3X12 screws as shown in figure 5.
- It is recommended to use cover to protect reader head and tape from any object directly falling on it.

Mounting of Reader head:

- The reader-head mounting bracket should be installed as per Figure 4 such that correct gap is maintained between the reader head and the scale.
- Make sure the grating sticker on the reader head matches the grating sticker on the tape.

Inspection of Mounting:

Move the slide over the full range of motion to make sure that full machine travel can be obtained without the reader head contacting the tape. Otherwise the reader will be damaged. Make sure that the plastic shim is removed after installation.

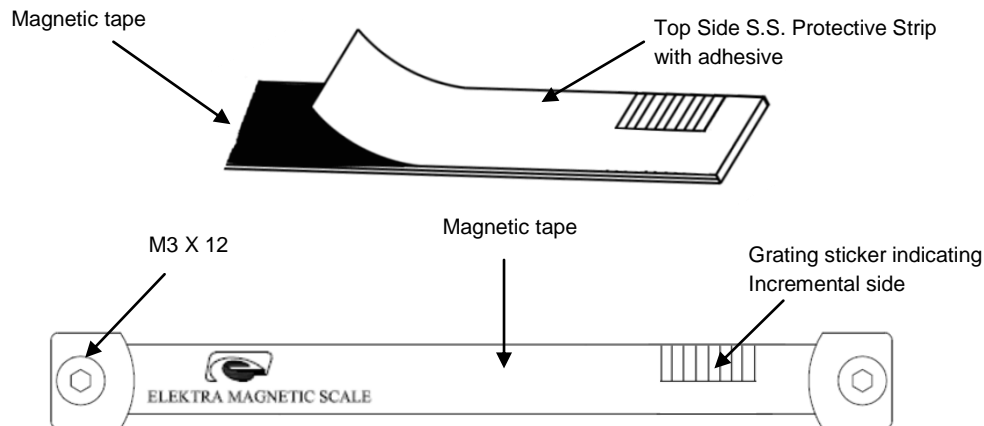

Figure 5

Cable Routing:

- Cable should be routed such that it does not come in between the machine moving parts.
- The bending radius should not be less than 60mm as shown in the figures.
- The encoder cables should not be routed close to high power or high voltage switching sources.
- Where extension leads are used the connectors should be mounted clear of any source of liquid contamination.

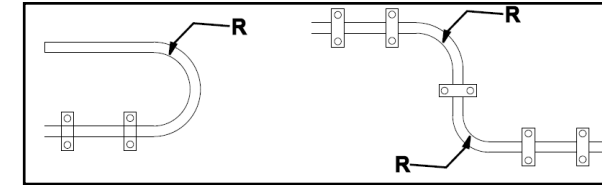

Figure 3

Safety:

- Avoid using the magnetic stand or any permanent magnet close to the magnetic tape any time during its use or during maintenance. This may damage the magnetic tape permanently.

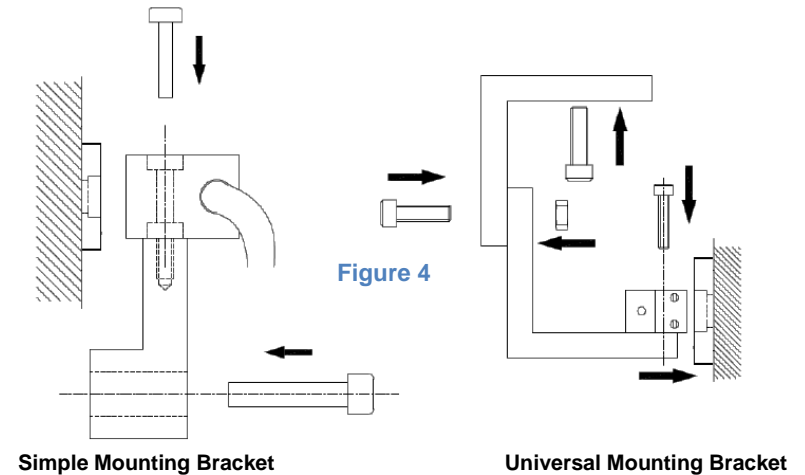

Figure 4